

Matière inox 304L ou 316L svt demande client
 finition microbillée ou peint svt demande client

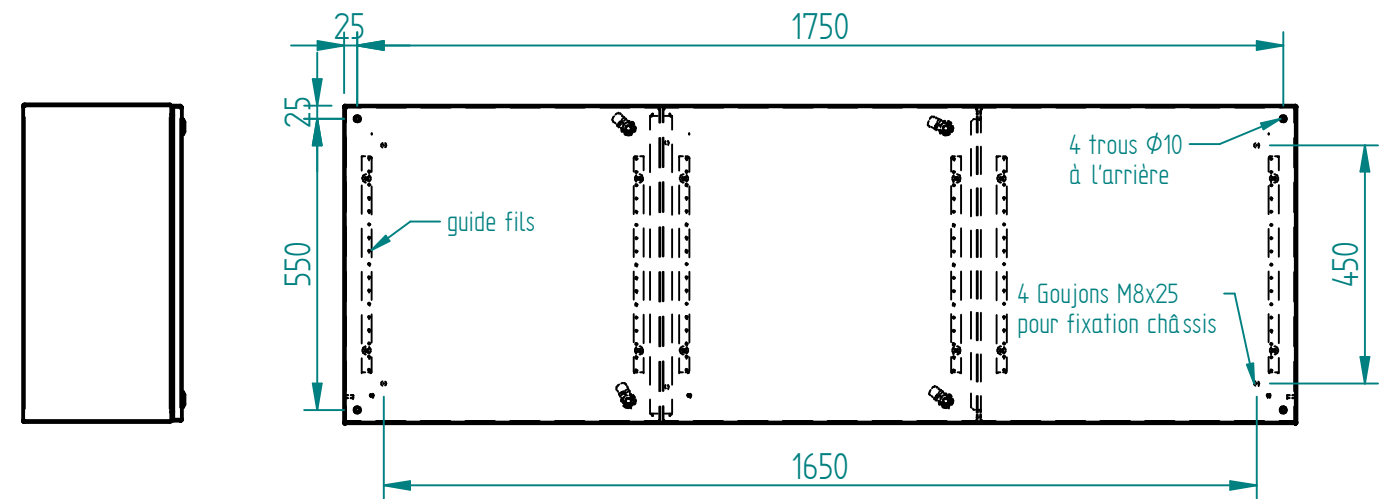

Joint EPDM extrudé 20x11

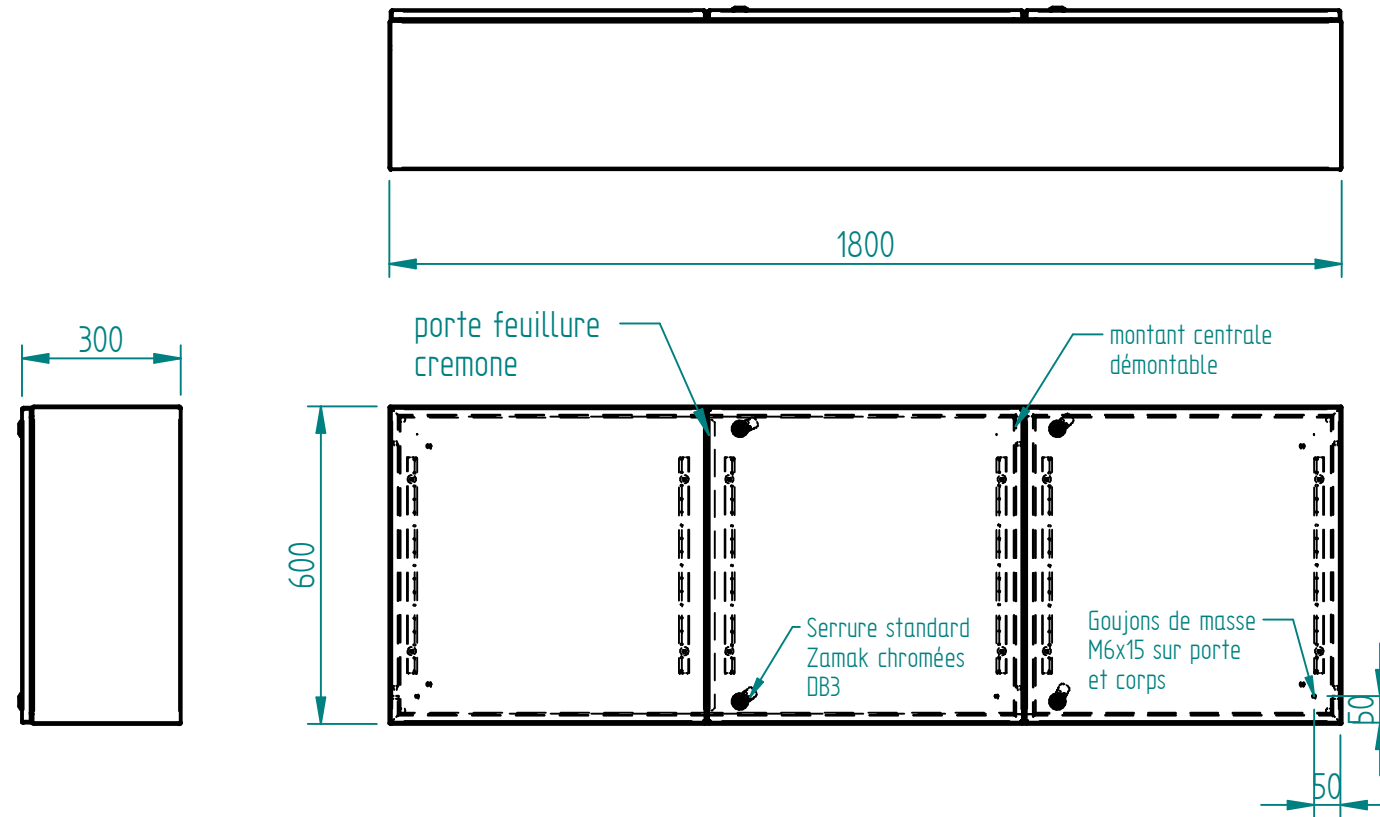
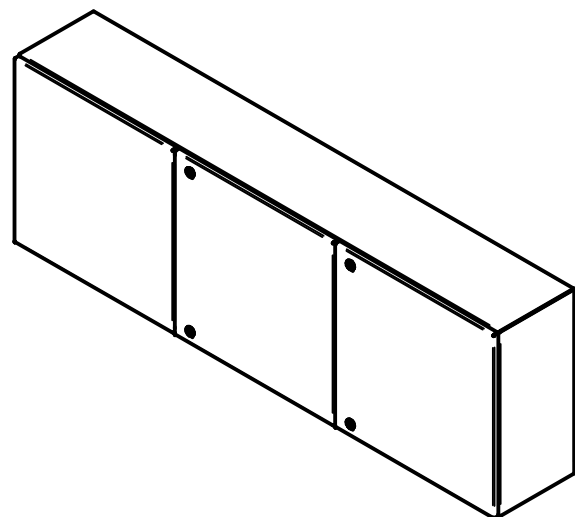

| Ind | Nom | Date | Commentaires |
|----------------------|--------------------|--|--------------|
| Matière : | | Nom du projet : COFF-600x1800x300 | |
| Echelle : 1:14.29 | Feuille : 1 / 1 | Client : | |
| | | Document n° : CXPN601830 ou CYPN601830 | |
| MARBORE | | | |